

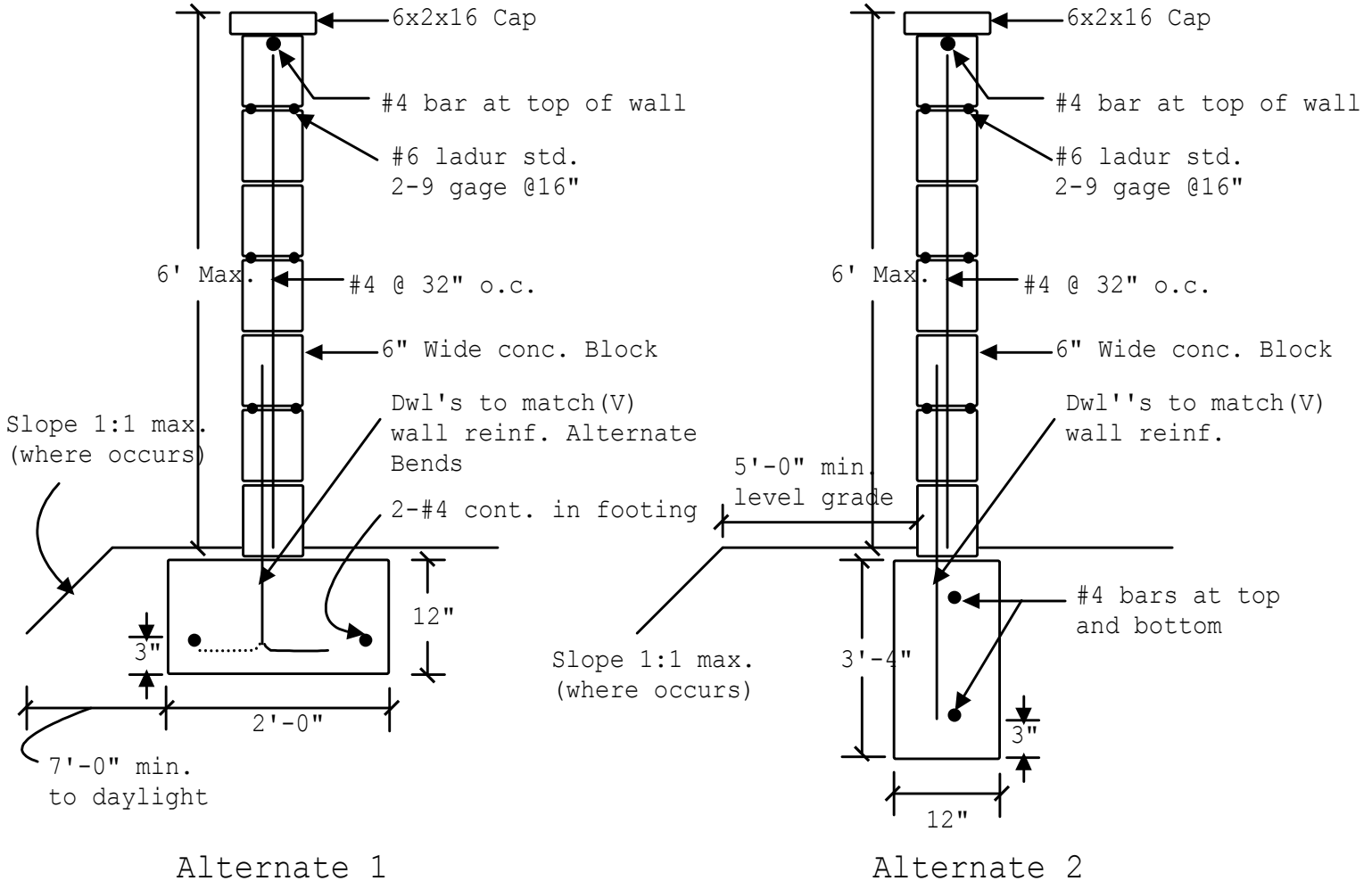

City of El Cajon
Building Division
 200 E. Main St.
 El Cajon, CA 92020
 Phone: (619) 441-1726, 1727

Block Fence Detail

(Based on City of San Diego Master Plan 47A)



Design Criteria:

1. Allowable soil bearing pressure = 1000 PSF minimum.
2. Allowable lateral passive pressure = 100 PSF minimum.
3. Seismic zone = 4, soil profile type sd, seismic source type "a" >5km.
4. Wind loads based on 70 MPH wind speed.
5. See reverse side for construction specifications.

Note:

The Building code exempts fences from requiring a building permit if the fence is not over 6 feet in height. Please be advised that zoning regulations governing fence height still apply.

Block Fence Construction Specifications

1. All material and workmanship shall conform to the requirements of the building code as currently adopted by the City of El Cajon.
2. Concrete shall attain a compressive strength of 2,000 PSI minimum at 28 days.
3. Concrete block units shall be medium weight units conforming to ASTM C90, Type 1 (latest revision), F'm = 1500 PSI.
4. Mortar shall be type S conforming to ASTM C270 or C1142 with a compressive strength of 1,800 PSI. minimum at 28 days.
5. Grout shall be composed of the following ratio by volume: 1 part portland cement, 3-parts pea gravel, and sufficient water for pouring without segregation of grout constituents (minimum compressive strength of 2,000 PSI at 28 days).
6. All reinforcing steel shall comply with ASTM A 615, grade 40 for #4 bars and Grade 60 for # 5 bars. Vertical steel shall be centered in the concrete block cell in which it is located.
7. Wall joint reinforcing steel shall be dur-o-wal wire conforming to ASTM A82 and ASTM A641 - class 3 finish. Minimum lap splice of joint reinforcement shall be 12 inches.
8. All cells containing reinforcing steel shall be solid routed.
9. All horizontal wall reinforcing bars shall be placed in bond beam units. All joint reinforcing shall be placed in the mortared bed joint.
10. All grout shall be consolidated by vibrating immediately. Reconsolidate grout after initial water loss but before plasticity is lost to insure adequate consolidation.
11. Minimum lap splice of reinforcing bars shall be 40 bar diameters.
12. Concrete block unit are to be staggered (common bond) and are to have the vertical continuity of the cells unobstructed.
13. All footings must extend into firm undisturbed natural soil or soil which has been compacted to at least 90 percent maximum density. Compaction reports for fill areas must be presented to the building inspector at time of foundation inspection (where applicable).
14. These wall shall not be constructed on expansive soil (expansion index greater than 20) unless the soil has been specially prepared in accordance with recommendations of a civil or geotechnical engineer. These walls shall not be constructed on liquefable soils or other soils of profile type Se or Sf.
15. These walls may not be constructed within 5 km of a know seismic source of type "B".
16. Provide vertical control joints at 30'-0" on center maximum.
17. Fence design includes 1/2 inch of plaster on each side of the wall. No finishes with a total weight greater than 13 psf (summation on both sides of the wall) are allowed.